

User's manual

Message display

TA 125



manual_ta125_v2.0.0.doc, rev. 3

and Text interface

TI 125

	Gönnheimer Elektronik GmbH		Dr.-Julius-Leber-Straße 2 67433 Neustadt/Weinstraße Postfach 10 05 07 67405 Neustadt phone: +49 (6321) 49919- 0 fax: +49 (6321) 49919 - 41
	http://www.goennheimer.de Email: info@goennheimer.de		

Contents

1	Operation instruction for explosion protected control panels	3
2	Message display TA125	4
2.1	Short Description.....	4
2.2	Application.....	4
3	Installation and Connection	5
3.1	Mounting	5
3.2	Electrical terminals	6
3.2.1	3.2.1 Terminals of TA125	7
3.2.2	3.2.2 Terminals of TI125.....	7
3.2.3	Connection to SIMENS SIWAREX weighting system	8
4	Operation manual.....	9
4.1	Display	9
4.2	Internal (hidden) Configuration keys.....	9
4.3	Starting.....	9
4.4	Reset – restore the ex works configuration	10
4.5	Parameter input /configuration with RS232 / RS485- interface (Direct Character).....	10
4.5.1	Data format	11
4.5.2	Protocol.....	11
4.5.3	Device address	11
4.5.4	Twelve binary inputs.....	11
4.6	Parameter input and Configuration with PROFIBUS DP	12
4.6.1	Configuration.....	12
4.6.2	Display modes	12
4.6.3	Data format	12
4.6.4	Protocol.....	13
4.6.5	Compact mode.....	14
4.6.6	Device address	15
4.6.7	Indicators on the Profibus- module.....	16
4.7	Parameter input and configuration with MODBUS- interface	17
4.7.1	Display modes	17
4.7.2	Data format	17
4.7.3	Device address	18
4.7.4	Compact mode (PV- mode).....	18
4.8	ASCII- Control characters	20
4.8.1	Format text (Function 8)	21
4.8.2	Working with variables (function 11, 12).....	21
4.8.3	Storing text pages (Function 13,14)	21
4.8.4	Binary output (function 15).....	21
5	Appendix	22
5.1	Technical Details.....	22
5.2	Dimensions	23
5.3	Type code	24
5.4	Block diagram	24
5.5	ASCII- character set of TA125	25

1 Operation instruction for explosion protected control panels

Application and standards

This instruction manual applies to explosion protected control panels of type of protection types below. This apparatus is only to be used as defined and meets requirements of EN 60 079 particularly EN60 079-14 "electrical apparatus for potentiality explosive atmospheres". It can be used in hazardous locations which are hazardous due to gases and vapours according to the explosion group and temperature class as stipulated on the type label. When installing and operating the explosion protected distribution and control panels the respective nationally valid regulations and requirements are to be observed.

General Instructions

The control panel has to have a back-up fuse as stipulated. The mains connection must have a sufficient short circuit current to ensure safe breaking of the fuse. To achieve an impeccable and safety device operation, please take care for adept transportation, storage and mounting, as well as accurate service and maintenance. Operation of this device should only be implemented by authorised persons and in strict accordance with local safety standards. The electrical data on the type label and if applicable, the "special conditions" of the test certificate PTB 98 ATEX 1488 are to be observed.

For outdoor installation it is recommended to protect the explosion protected distribution and control panel against direct climatic influence, e.g. with a protective roof. The maximum ambient temperature is 40°C, if not stipulated otherwise.

Intrinsically Safe Circuits

Erection instructions in the testing certificates of intrinsically safe apparatus are to be observed. The electrical safety values stipulated on the type label must not be exceeded in the intrinsically safe circuit. When interconnecting intrinsically safe circuits it is to be tested, whether a voltage and/or current addition occurs. The intrinsic safety of interconnected circuits is to be ensured. (EN 60079-14, section 12)



Safety Measures: to read and to comply

Work on electrical installations and apparatus in operation is generally forbidden in hazardous locations, with the exception of intrinsically safe circuits. In special cases work can be done on non-intrinsically safe circuits, on the condition that during the duration of such work no explosive atmosphere exists.

Only explosion protected certified measuring instruments may be used to ensure that the apparatus is voltage-free. Grounding and short circuiting may only be carried out, if there is no explosion hazard at the grounding or short circuit connection.



2 Message display TA125

2.1 Short Description

The field text display TA125 indicates arbitrary messages, warnings or hints in the hazardous area zone 1. It's large (58 x 244 mm²), reflective display with a figure height of 15 mm can easily be read up to a distance of five meters. The display is organised into 4 rows with 40 characters per row.

The TA125 receives the messages for instance from a PC or DCS located in safe area. The interface TI125 serves as intrinsically safe barrier and power supply. It can be equipped with several bus modules (RS232, RS485, RS422, Profibus DP, Interbus and Modbus). The distance to the TA125 could be up to 300 meters with a data rate of 38,4 kbit/s. Use wire with a bigger diameter for longer distances.

It is possible to connect many text display to one bus (theoretical up to 255). Each one with a different text content.

Additionally the TA125 has an intrinsically safe passive alarm output. With this it is possible to connect a further alarming device. With the three digital inputs you can acknowledge a message or an alarm or you can request further information on the spot in hazardous area.

The TA125 stores up to 32 kByte of messages in an internal EEPROM. You can program the stored messages with the bundled windows software "TEXT LINK". There are two ways to display the stored texts: the serial interface or applying a defined bit pattern to binary address inputs of the TI125 (option).

2.2 Application

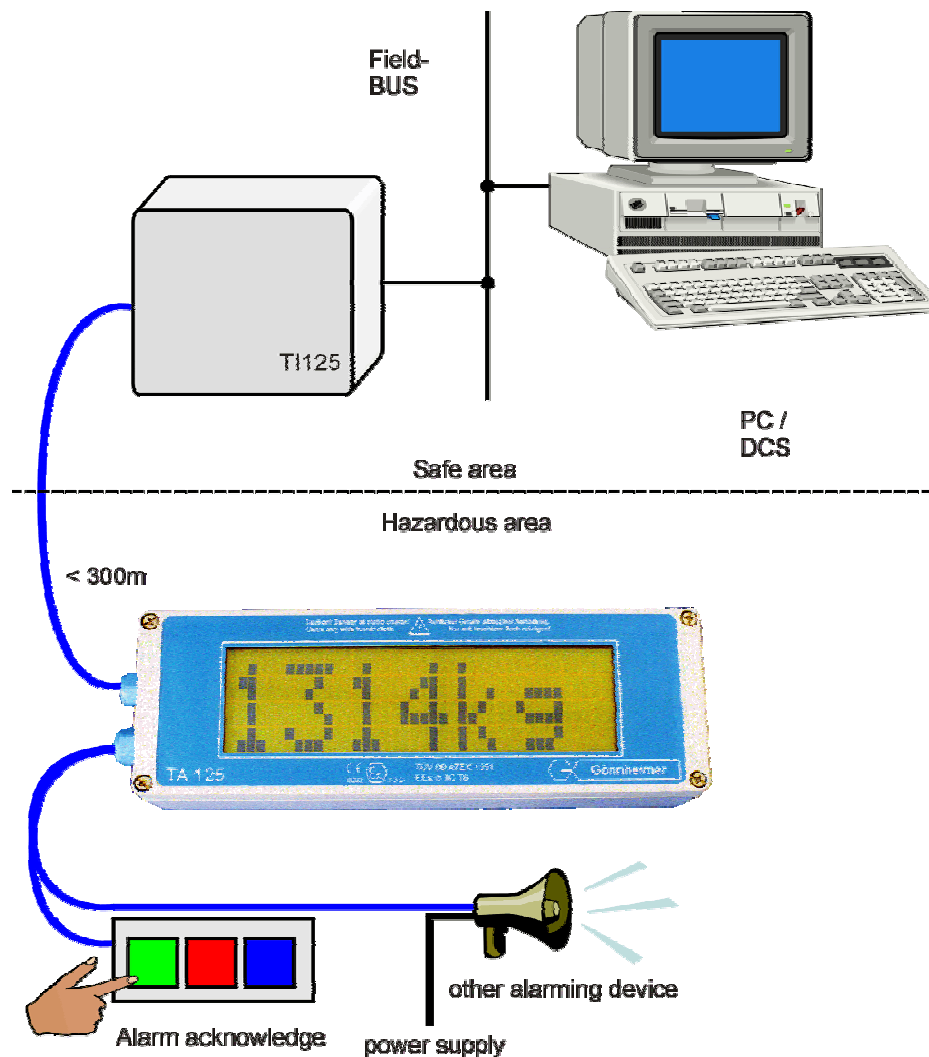

Figure 1 Example: Application TA125 / TI125

3 Installation and Connection

3.1 Mounting

The TA125 is predicated for mounting and use in hazardous area zone 1. Fix the TA125 with the drillings on the rear side of the housing. Choose a solid place to install the display in the field area.

The **interface TI125 must be mounted in safe area!** We recommend a 35 mm rail acc. EN 50022 for mounting.



Note

Observe local safety guidelines and the regulative EN 60079 especially the regulative EN 60079-14.

Regard the distances of mounting drillings on the figure below:

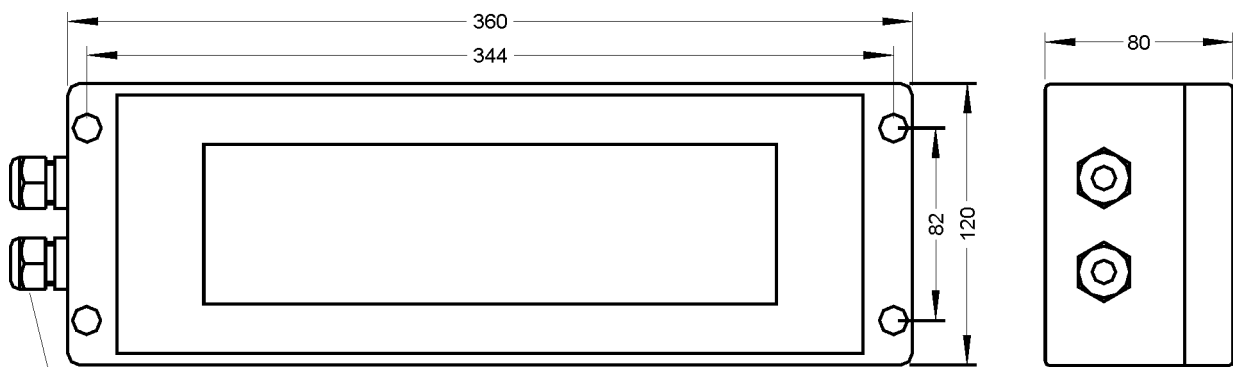

M16 x 1,5; SP: 5-10

Figure 2 dimensions, mounting schematics

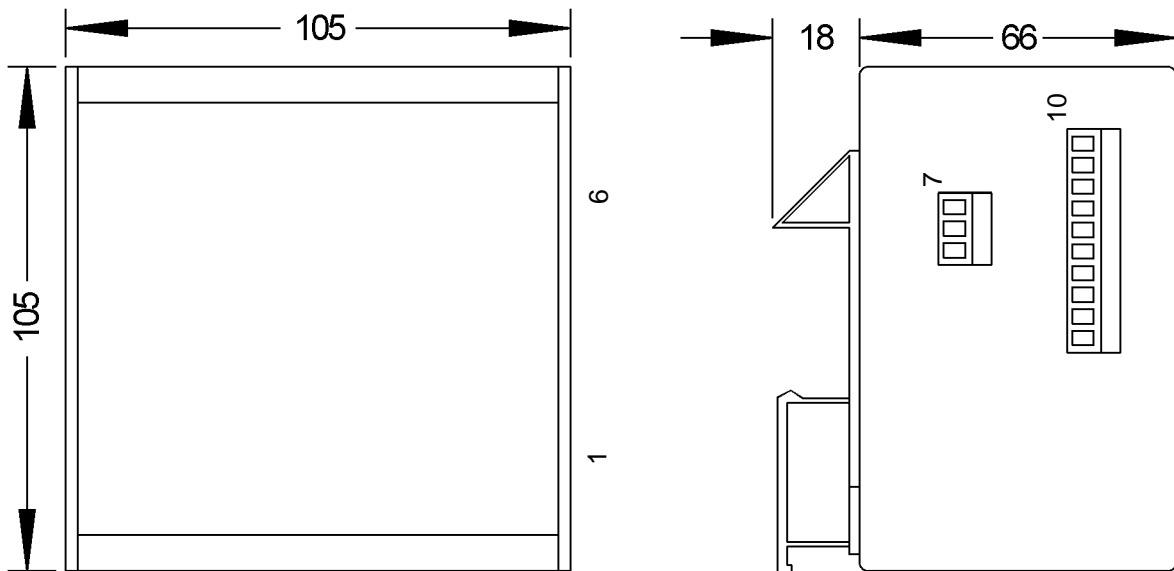

Figure 3 dimensions TI125, with terminal numbers

3.2 Electrical terminals

Connect the TA125 to the Interface TI125 according the figure below. Additionally it is possible to connect 3 passive push-buttons.

The TI125 has on its intrinsically safe side a power supply terminal (terminals 1,2) and a serial connection (terminals 3,4) to the TA125.

The non intrinsically safe terminals are mains and data interface. See on the figure below:

 **Note**

Please note the following Standard of Compliance: TÜV 00 ATEX 1551, TÜV 00 ATEX 1552 and the regulative EN 60079-14.

 **Note**

Do not exceed terminal safety limits of each terminal. See limits in technical details or declarations of conformity TÜV 00 ATEX 1551 and TÜV 00 ATEX 1552.

 **Note**

The use of cat 7 network cable is recommend by using the wire between TI125 and TA125 in EMC areas .

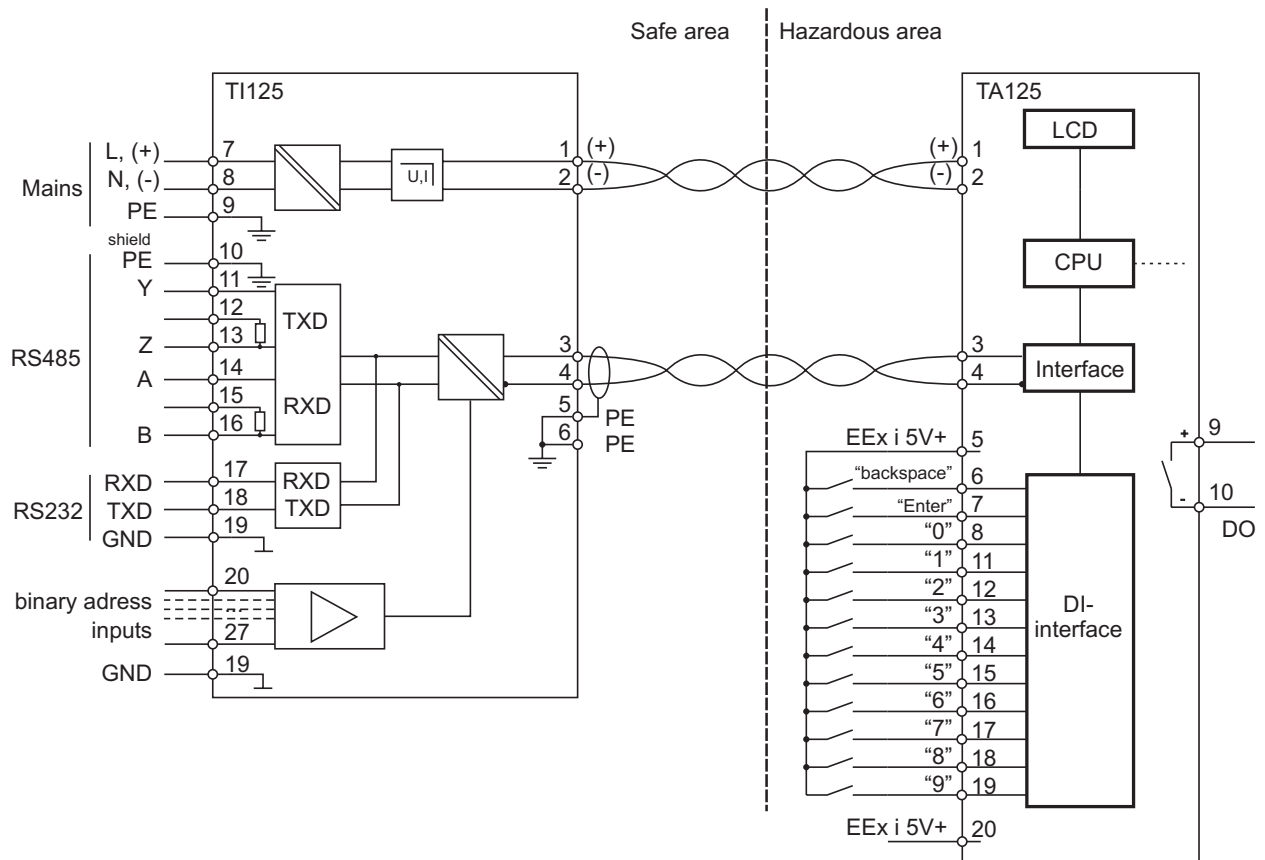

Figure 4 Detailed Block diagram connection TA125 and TI125

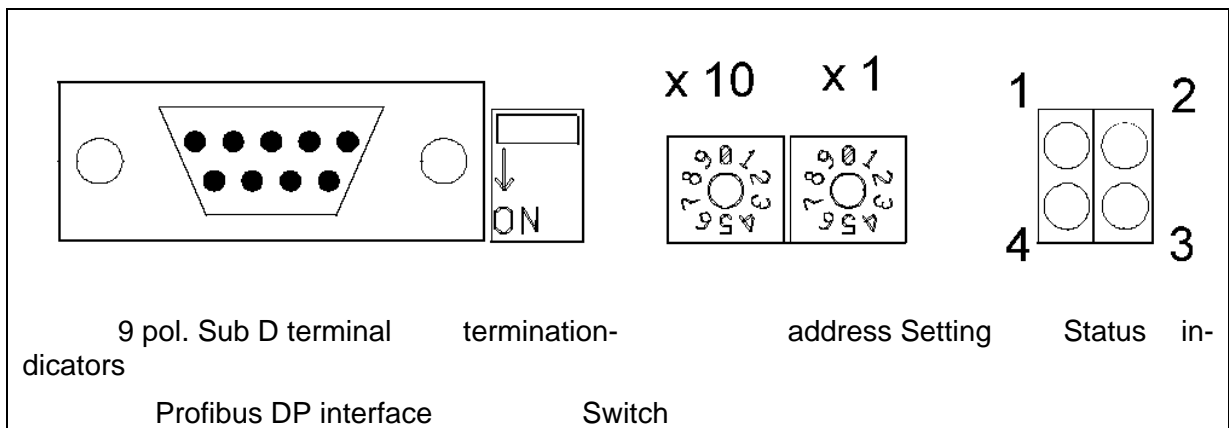

Figure 5 Terminals and switches on the Profibus module

3.2.1 3.2.1 Terminals of TA125

Terminal	Comment	
1 (+)	Power supply for TA125	A 2 x 2 x 0,25 mm ² twisted pair- cable is recommend.
2 (-)		
3, 4	Serial interface, Twisted pair	
5-6, 5-7, 5-8 5-11, 5-12, 5-13, 5-14, 5-15, 5-16, 5-17, 5-18, 5-19	Active binary inputs, only to connect passive switches	
9 (+)	Passive Open –Collector- Binary output, galvanic separated to any current circuit up to a voltage of 60V.	
10 (-)		
20 (+)	+ 5 V EEx i- Voltage	

3.2.2 3.2.2 Terminals of TI125

Intrinsically safe outputs (blue terminal plug)	
Terminal	Comment
1 (+), 2 (-)	Intrinsically safe power supply for TA125
3,4	Intrinsically safe serial interface to TA125

Non- intrinsically safe inputs	
Terminal	Comment
7 (L) (+)	Mains power supply, type depending Attention! The voltage of the DC- version is 24 V DC !!
8 (N) (-)	
9 PE	Protective ground (CCITT)
10 PE	Shield connector
11 (Y)	RS485 Transceiver
13 (Z)	Connect Terminal 11 and 12 to activate internal terminal resistor (120 Ω)
14 (A)	RS485 Receiver
16 (B)	Connect Terminal 14 and 15 to activate internal terminal resistor (120 Ω)
17 (TxD)	RS232 Data output (Transmit Data)
18 (RxD)	RS232 Data input (Receive Data)
19 (GND)	Ground RS232
20-27	Binary address inputs, U = 24 V DC, active to ground (te. 19)

3.2.3 Connection to SIEMENS SIWAREX weighting system

Connect the SIEMENS SIWAREX weighting system to the RS485- interface. Consider using the shorts to RTa and RTb. See drawing below:

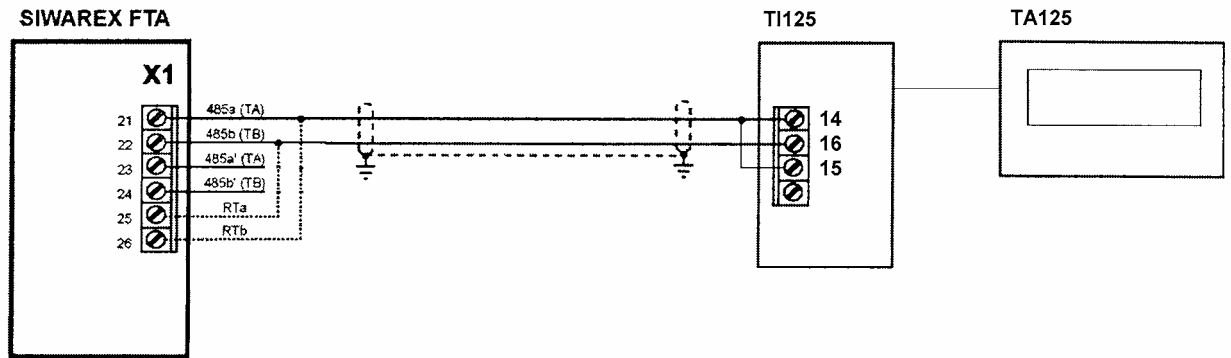

For proper working it is necessary to choose the SIWAREX- protocol in the TA125 config.

4 Operation manual

To change the configuration of the TA125 uses the internal keys. To set characters to the display use the software "Textlink", which is included the TA125, or your favourite terminal program.

4.1 Display

The display of the TA125 has 4 rows with 40 characters per row. The TA125 can be switched to a bigger font by an ESC- sequence. The large text has a character height of 65 mm. Texts with more than 6 characters scroll through the display.

4.2 Internal (hidden) Configuration keys

The configuration keys are located inside of the TA125- housing. To get them remove the four screws on the top of the housing and open the TA125. The keys are located on the small PCB with the blue terminal socket on the rear side of the cover.

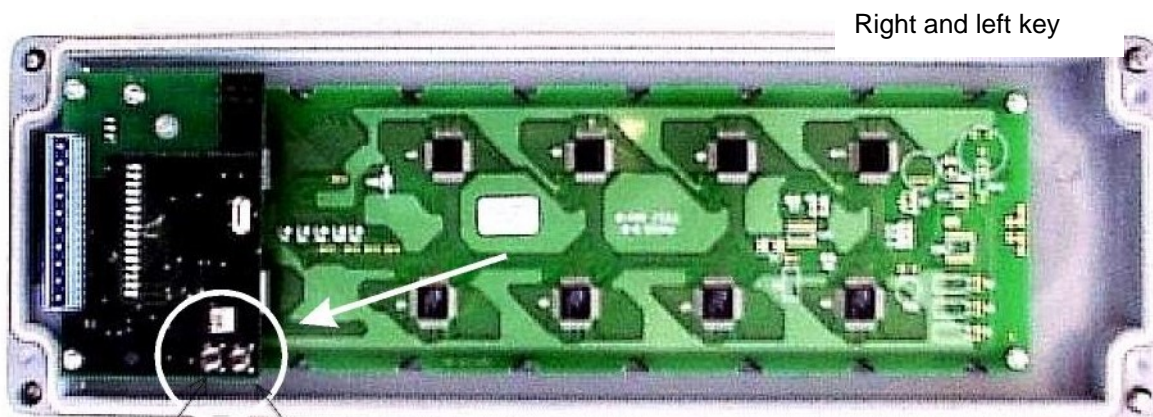

Figure 6 Rear side of the cover with the internal configuration keys

4.3 Starting

After a correct connecting of the TA125 to the T1125 and power on the TA125 shows the figure below:

```

TA125
Gönnheimer Elektronik GmbH
„Version number“
Checking EEPROM data !

```

after that the display shows

```

TA125
Gönnheimer Elektronik GmbH
„Version number“
Connecting to interface !

```

The TA125 now tries to build up a communication to the T1125.

Next the display will be cleared and the transmitted text will be shown.

4.4 Reset – restore the ex works configuration

Use the following procedure to reset the EPROM text memory and to restore the ex works configuration:

- (1) Replace the cover of the TA125 and pull of the plug to turn off the display
- (2) Press and hold both configuration keys on the rear side of the cover
- (3) Turn on the display by reconnecting the plug
- (4) Release the configuration keys – the display shows RESET
- (5) Acknowledge the reset by pressing any of the keys

After that the TA125 format the internal EPROM and restores the ex works configuration. The TA125 starts again.

4.5 Parameter input /configuration with RS232 / RS485- interface (Direct Character)

You can enter basic configuration of the TA125 by the internal configuration keys.

To enter the basic settings use the two keys on the rear side of the display PCB. We define the key closer to the terminals as the left and the other as the right key.

Start the configuration menu by pressing both keys. Generally the left key will modify the tag and the right key will confirm the setting and show the next tag.

The display shows:

```
Set device parameters
Language =
```

Here you can select the user's language. The text display is configured ex works and can start immediately. The default parameters has an * in the table below:

Menu tag	Possible contents	Comment
Language	Deutsch*, English, French, Dutch	
Data format:		
Bit	n = 7, 8*	Number of data bits for the serial communication
Parity	no*, even, odd	Parity of the serial communication
Stop bits	n = 1*, 2	Number of stop bits
Baud rate	n = 600, 1200, 2400, 4800, 9600*, 19200, 38400 bit/s	Speed of the serial communication
Protocol:		
Protocol	No, STX/ETX, CR/LF*	STX/ETX: Each received character sequence must start with the control character "STX" and end with an "ETX". CR/LF: Each received character sequence ends with the control character "CR/LF". See also Protocol SIWAREX: protocol of SIEMENS SIWAREX weight system for direct talking to SIWAREX module
Protocol answer	no*, Echo, ACK/NACK	If you use one of the above protocol, then the answer will be by Echo: the revived characters will be sent back ACK/NACK: An "ACK" control character will be returned, if all characters are received well otherwise a "NACK" will be returned

Skip	n = 0* ...9	Number of the first n characters of a data sequence which will be ignored.
Device address:		
Address length	n = 0* ...3	n is the number of the digits of the device address. If n=0 the address input is disabled.
Device address	0* bis 255	If you use more than one Textdisplay on the same bus, you must identify the display device by its device address
Watchdog time	0* bis 999	The watchdog timer determinates a broken data wire. If the TA125 gets no data in watchdog time, the TA125 will show " No connection to host !". After receiving data again the message disappears.
Settings ok	Yes / No	If "Yes" is entered all settings will be confirmed and the configuration menu will be left. Otherwise the menu starts from the beginning.

4.5.1 Data format

The default data format of the serial interface is 8 bit. That can be changed to 7 data bits. The user may change the parity, stop bit and serial speed settings too.

4.5.2 Protocol

The serial interface can manage several receive protocols, see the table below:

DATA	(1)
HEADER DATA	(2)
DATA CR/LF	(3) *
HEADER DATA CR/LF	(4)
STX DATA ETX	(5)
HEADER STX DATA ETX	(6)

CR = Carriage Return (0Dh), LF = Line Feed (0Ah), STX = Start of Text (02h), ETX = End of Text (03h)

The data contains text data and format characters for instance Text page recall, show variable etc. The header contains the display device address.

4.5.3 Device address

It is possible to connect several display devices to one bus. In that case every device get its individual device address (0* ... 255) in menu tag (10). This address must be sent in the head of each data transmission to select the right device.

The display devices TA125 understand the address "0" as Broadcast. That means that every display device on the bus receives and displays the message.

Enter the address length at menu tag (9). If you use the transmission protocol (1), (3) or (5) choose "0" as address length.

4.5.4 Twelve binary inputs

The TA125 has three binary inputs, to acknowledge an alarm for instance. If a signal on input x occurs the TA125 sends immediately the ASCII character x to the host. If the user releases the button the TA125 sends the ASCII "0" 30(hex).

With serial RS232 / RS485- interface it is not possible to use this inputs, if more than one unit is connected to the network.

4.6 Parameter input and Configuration with PROFIBUS DP

Enter basic configuration of the TA125 by the internal configuration keys. Later on you can modify the configuration by software.

4.6.1 Configuration

Start the configuration menu by pressing both keys. Generally the left key will modify the tag and the right key will confirm the setting and show the next tag.

The display shows:

```
Set device parameters
Language =
```

You can select here the user's language. The text display is configured ex works and can start immediately. The default parameters have an * in the table below:

Menu tag	Possible contents	Comment
Language	Deutsch*, English, French, Dutch	
Digital inputs	DI12 DI0 000000000000	"0" means normal open mode "1" means normal closed mode
Settings ok	Yes / No	If "Yes" is entered all settings will be confirmed and the configuration menu will be left. Otherwise the menu starts from the beginning.

4.6.2 Display modes

From the software version 2.0 the TA125 has two different display modes. The *general mode* the TA125 works according to ISO/IEC 6429. With this general mode all text functions of the TA125 can be used.

Additionally works the TA125 in compact mode. In the mode the TA125 gets in a short form the page number to recall out in the internal memory and the actual value of all eight variables usable on one page.

The data exchange format is equal in each mode.

4.6.3 Data format

The TA125 works in combination with the TI125 as Profibus- Slave. It possesses 34 Byte Data_Out and 4 Byte Data_In.

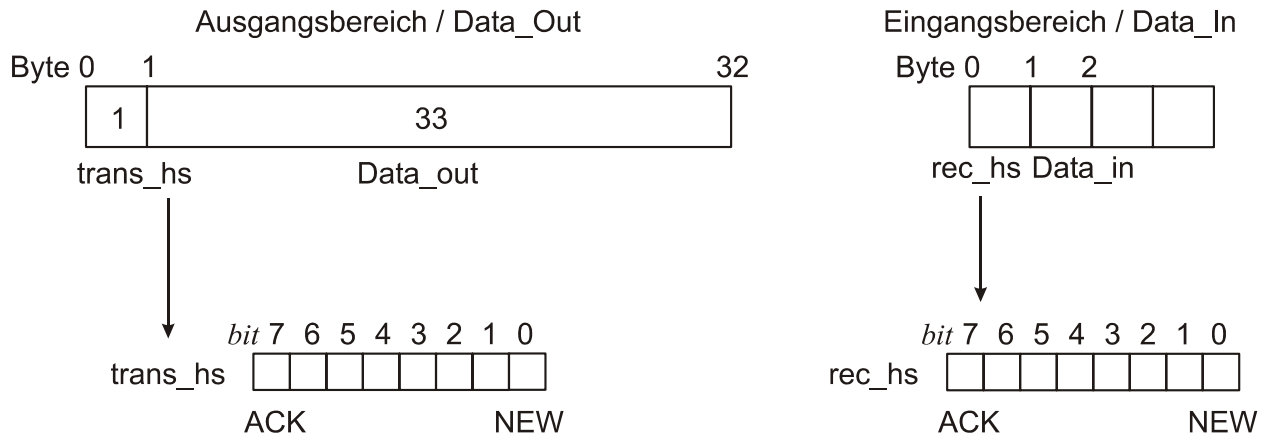

4.6.4 Protocol

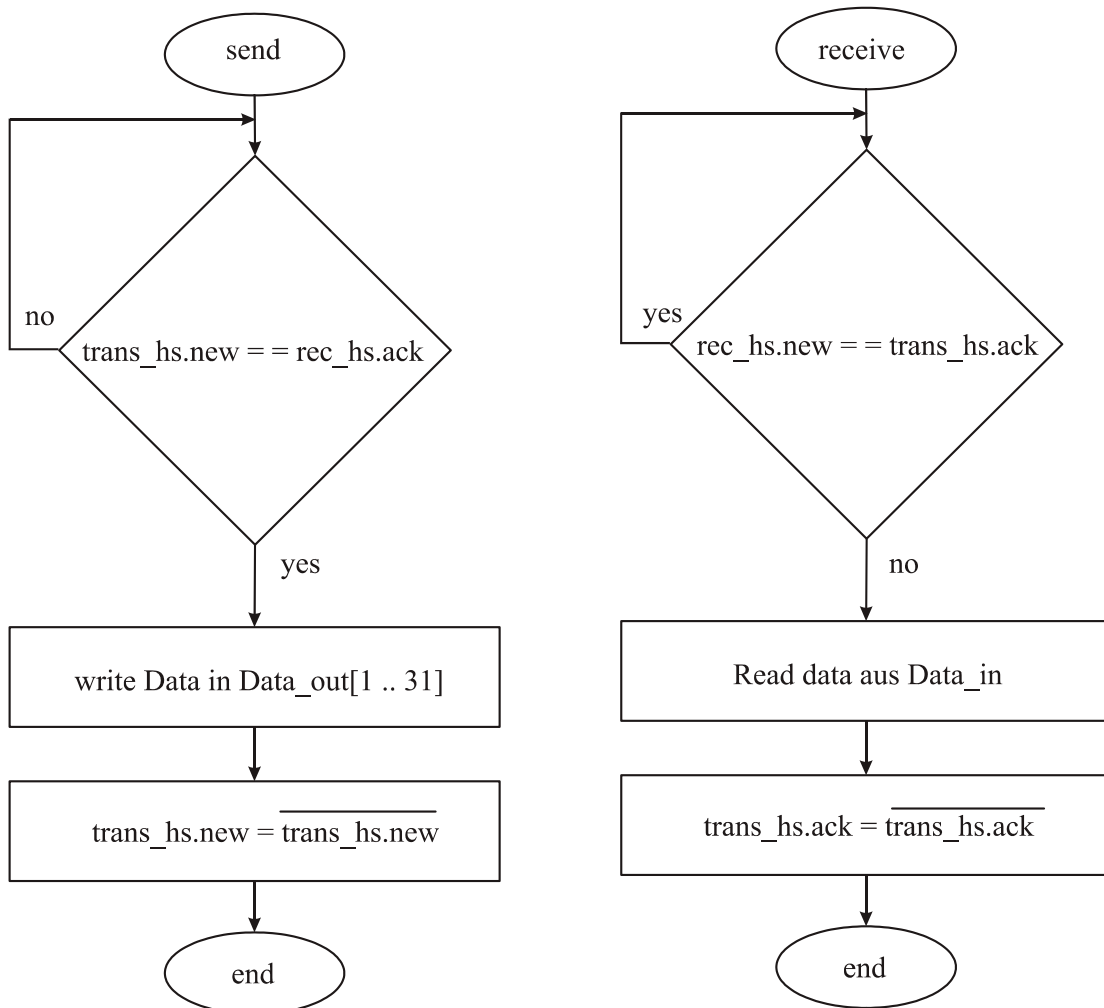

Send

First check if the TA125 is reading data in Data_out. The Ta125 is reading data as long as trans_hs.new is unequal to rec_hs.ack.

Next write data into Byte 1 up to 33 into Data_out. If you have less than 33 then fill up the Data_out with zeros.

Next invert the trans_hs.new to indicate that the TA125 can read the data. If the slave has received the data, it will indicate that by inverting the rec_hs.ack.

Receive

A new message has arrived, if rec_hs.new is unequal to trans_hs.ack. After reading the data out of Data_in the master has to invert the trans_hs.ack to indicate that it is ready to receive.

4.6.5 Compact mode

The software-Version 2.0.0 of the TA125/TI125 contains a new indicator mode as well as the introduction of binary variable to the announcement in the TA125.

With this compact mode (PV- mode) it is possible to recall most efficient pages from the internal memory and set the variables of 1-8 to new values.

In this new indicator mode the profibus DP memory is divided as follows:

Output data

The output-area of the profibus DP covers 34 bytes. These are used for the selection of the page which can be indicated and for filling variables with values. The variables are coded according to DIN 19245 part 2.

Adress	Name	Function
0	Trans_hs	Contains different Bits to control the TA125, see details below:
1	Page_No	No. of the recalled page
2 - 5	Var1	Value of variable 1
6 - 9	Var2	Value of variable 2
10 - 13	Var3	Value of variable 3
14 - 17	Var4	Value of variable 4
18 - 21	Var5	Value of variable 5
22 - 25	Var6	Value of variable 6
26 - 29	Var7	Value of variable 7
30 - 33	Var8	Value of variable 8

1. Trans_hs:

Bit	Name	Function
0	New	There is new data for the TA125
1	Mode	Defines the display mode 0 = common general mode (only string variables) 1 = PV- Mode (binary variables)
2	Clear_restart	Reset of the restart_flag
3	DA	Set the digital Output (DO) on TA125 0 = DO open 1 = DO is closed
4	-	Reserved
5	-	Reserved
6	-	Reserved
7	Ack	DP Master has recognized data

2. Page_No:

The page of No will be displayed.

3. Var1 ...Var2:

Values of the variable 1 to 8. The values must be coded according to DIN 19245 Teil2. The data types are visible string (max 4 characters), Boolean, Integer8, Integer16, Integer32, Unsigned8,

Unsigned16, Unsigned32, Floating-point, time of day (without date) and Bit_string. For every variable type are 4 bytes at the disposal. If the variable don't need all 4 bytes only the bytes with the lower addresses (e.g. Integer8 in Var1 it only the byte at address 2 used) are used.

Input data

The input data range of the profibus DP covers 4 bytes. These are used for the transmission of status information and the digital initial conditions from the TA125 to the profibus master.

Adress	Name	Function
0	Rec_hs	Contains different bits to control the TA125 see description below:
1	Data_in	Digital inputs of the TA125 ASCII coded
2 – 3	Data_raw_in	Digital inputs of the TA125 coded as Bit- array

1. Rec_hs:

Bit	Name	Function
0	New	New data for DP Master available
1	Restart-Flag	The TA125 has made a restart
2	Live bit	=1 if connection TI/TA ok =0 , if connection TI/TA not ok
3	-	Reserved
4	-	Reserved
5	-	Reserved
6	-	Reserved
7	Ack	TA125 has recognized last data

2. Data_in:

Keys (digital inputs) of the TA125 ASCII coded: „0“ until „9“, BS und Enter.

3. Data_raw_in:

Keys (digital inputs) of the TA125 coded as Bit- array (Bit 0 bis 11). The “normal open” normal closed” mask in the TA125 are used for these bits.

4.6.6 Device address

Set the device address with the two revolution switches. The address is built by:

$$\text{Address} = (\text{left switch} * 10) + (\text{right switch})$$

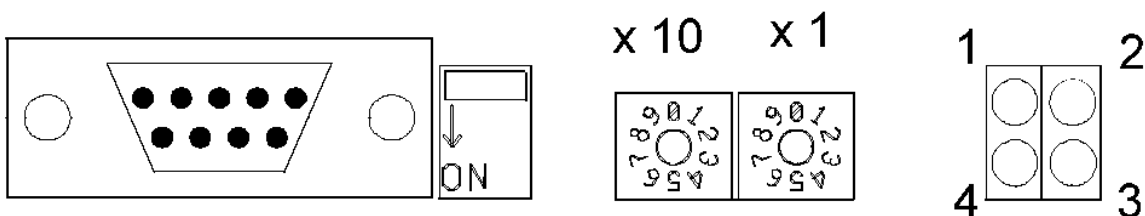

Figure 7 Switches and indicators Profibus- module



Hint

Using Profibus DP the addresses 01 and 02 are reserved and are not available.

4.6.7 Indicators on the Profibus- module

LED- indicators on figure 7.

1. Not used
2. On-Line
3. Off-Line
4. Field bus Diagnose

Name	colour	Function
Field bus diagnose	Red	<p>Indicates certain faults on the Field bus side:</p> <p>Flashing Red 1 Hz: Error in configuration: IN and/or OUT length set during initialisation of the module is not equal to the length set during configuration of the network.</p> <p>Flashing Red 2 Hz: Error in User Parameter Data: The length/contents of the user Parameter set during initialisation of the module is not equal to the length/contents set during configuration of the network.</p> <p>Flashing Red 4 Hz: Error in initialisation of the Profibus communication ASIC.</p> <p>Turned Off: No diagnostics present.</p>
On-Line	Green	<p>Indicates that the module is On-Line on the field bus.</p> <p>Green: Module is On-Line and data exchange is possible.</p> <p>Turned Off: Module is not On-Line.</p>
Off-Line	Red	<p>Indicates that the module is Off-Line on the field bus.</p> <p>Red: Module is Off-Line and no data exchange is possible.</p> <p>Turned Off: Module is not Off-Line.</p>

4.7 Parameter input and configuration with MODBUS- interface

You can enter basic configuration of the TA125 by the internal configuration keys.

To enter the basic settings use the two keys on the rear side of the display PCB. We define the key closer to the terminals as the left and the other as the right key.

Start the configuration menu by pressing both keys. Generally the left key will modify the tag and the right key will confirm the setting and show the next tag.

The display shows:

```
Set device parameters
Language =
```

Here you can select the user's language. The text display is configured ex works and can start immediately. The default parameters has an * in the table below:

Menu tag	Possible contents	Comment
Language	German*, English, French, Dutch	
<i>Data format:</i>		
Bit	n = 7, 8*	Number of data bits for the serial communication
Parity	no*, even, odd	Parity of the serial communication
Stop bits	n = 1*, 2	Number of stop bits
Baud rate	n = 600, 1200, 2400, 4800, 9600*, 19200, 38400 bit/s	Speed of the serial communication
<i>Device address:</i>		
Device address	1* up to 247	If you use more than one text display on the same bus, you must identify the display device by its device address
Watchdog time	0* up to 999	The watchdog timer determinates a broken data wire. If the TA125 gets no data in watchdog time, the TA125 will show " No connection to host !". After receiving data again the message disappears.
Settings ok	Yes / No	If "Yes" is entered all settings will be confirmed and the configuration menu will be left. Otherwise the menu starts from the beginning.

4.7.1 Display modes

From the software version 2.0 the TA125 has two different display modes. The *general mode* the TA125 works according to ISO/IEC 6429. With this general mode all text functions of the TA125 can be used.

Additionally works the TA125 in compact mode. In the mode the TA125 gets in a short form the page number to recall out in the internal memory and the actual value of all eight variables usable on one page.

4.7.2 Data format

The TA125 in combination with TI125 works as MODBUS slave only. It has 100 HOLDING Registers output range

Registers in general mode

The TA125 uses only "Holding registers" to receive and characters and commands. The input buffer has 100 Registers(= 200 Characters). The registers are defined as below:

Register (Hex)	Access	Data format	Function
40001	R	Bit	Ctrl- Flags: Bit 0: Key 1 (terminal 6) Bit 1: Key 2 (terminal 7) Bit 2: Key 3 (terminal 8) Bit 3: Key 4 (terminal 11) Bit 4: Key 5 (terminal 12) Bit 5: Key 6 (terminal 13) Bit 6: Key 7 (terminal 14) Bit 7: Key 8 (terminal 15) Bit 8: Key 9 (terminal 16) Bit 9: Key 10 (terminal 17) Bit 10: Key 11 (terminal 18) Bit 11: Key 12 (terminal 19)
40002	R/W	2 byte Character field	Input field for Characters
40003	R/W	2 byte Character field	Input field for Characters
40004	R/W	2 byte Character field	Input field for Characters
.			
40065	R/W	2 byte Character field	Input field for Characters

Remarks

- The Register 40001 is assigned with (R) "read only", that means that only read access is possible
- Text data must be terminated with the character ASC(00)

4.7.3 Device address

Set the device address in the menu as shown in chapter 4.7

4.7.4 Compact mode (PV- mode)

The software-Version 2.0.0 of the TA125/TI125 contains a new indicator mode as well as the introduction of binary variable to the announcement in the TA125.

With this compact mode (PV- mode) it is possible to recall most efficient pages from the internal memory and set the variables of 1-8 to new values.

In this new indicator mode the modbus registers is divided as follows:

Registers in compact mode

The output-area covers 18 registers. These are used for the selection of the page which can be indicated and for filling variables with values. The variables are coded according to DIN 19245 part 2.

Register (Hex)	Access	Data format	Function
40001	R	Bit	Ctrl- Flags: Bit 0: Key 1 (terminal 6) Bit 1: Key 2 (terminal 7) Bit 2: Key 3 (terminal 8) Bit 3: Key 4 (terminal 11) Bit 4: Key 5 (terminal 12)

	R R/W R/W R/W	Bit	Bit 11: Key 12 (terminal 19) Bit 12: Restart- Flag Bit 13: Clear Restart- Flag Bit 14: Set Digital Output (1 = close) Bit 15: Mode (1 = PV- mode)
40002	R/W		Page No: Recall of page No in internal memory (page no. set in low byte, high byte is reserved)
40003	R/W	4 byte Character field	Variable 1
40004			
.			
40017	R/W	4 byte Character field	Variable 8
40018			

1. Mode Register:

Bit	Function
0 ..11	Indication of DI 1 ..12
12	Restart Flag
13	Reset of the restart_flag
14	Set the digital Output (DO) on TA125 0 = DO open 1 = DO is closed
15	Defines the display mode 0 = common general mode (only string variables) 1 = PV- Mode (binary variables)

4. Var1 ...Var8:

Values of the variable 1 to 8. The values must be coded according to DIN 19245 Teil2. The data types are visible string (max 4 characters), Boolean, Integer8, Integer16, Integer32, Unsigned8, Unsigned16, Unsigned32, Floating-point, time of day (without date) and Bit_string. For every variable type are 4 bytes at the disposal. If the variable don't need all 4 bytes only the bytes with the lower addresses (e.g. Integer8 in Var1 it only the byte at address 2 used) are used.

4.8 ASCII- Control characters

The TA125 works with control characters according ISO/IEC 642. These are listed in the table below:

No.	Function	*	Data „ESC [“ prefix	Example : ASCII HEX	Comment:
(1)	CURSOR NEXT LINE	1	Pn E	ESC [1 E 1B 5B 32 45	The Cursor jumps to the very left position of the next line
(2)	CURSOR PREV. LINE	1	Pn F	ESC [1 F 1B 5B 31 46	The Cursor jumps to the very left position of the previous line
(3)	CURSOR LEFT	1	Pn D	ESC [2 5 D 1B 5B 32 35 44	The Cursor jumps 25 positions left
(4)	CURSOR DOWN	1	Pn B	ESC [3 B 1B 5B 33 42	The Cursor jumps 2 line down
(5)	CURSOR RIGHT	1	Pn C	ESC [2 0 C 1B 5B 32 30 43	The Cursor jumps 20 positions right
(6)	CURSOR UP	1	Pn A	ESC [2 A 1B 5B 32 41	The Cursor jumps 2 line up
(7)	CURSOR ABSOLUT	1; 2	Pn1; Pn2 H	ESC [2 ; 1 2 H 1B 5B 32 3B 31 32 48	The cursor position is now 2 nd row, 12 th column
(8)	SET GR. RENDITION	0	Pn m	ESC [0 m 1B 5B 30 6D	The following characters will be dis- played normal
				ESC [1 m 1B 5B 31 6D	Toggle to large text display 1 line 6 columns
				ESC [5 m 1B 5B 35 6D	The following characters are flashing slowly (1 Hz)
				ESC [6 m 1B 5B 36 6D	The following characters are flashing fast (2 Hz)
				ESC [2 2 m 1B 5B 32 32 6D	Toggle to normal display (4 x 40 Characters)
				ESC [0 5 m 1B 5B 32 35 6D	The following characters are static (no flashing)
(9)	ERASE IN PAGE	0	Pn J	ESC [0 J 1B 5B 30 4A	The characters between Cursors and page end will be deleted
				ESC [1 J 1B 5B 31 4A	The characters between Cursors and page start will be deleted
				ESC [2 J 1B 5B 32 4A	Erase the hole page
(10)	ERASE IN LINE	0	Pn K	ESC [0 K 1B 5B 30 4B	The characters between Cursors and line end will be deleted
				ESC [1 K 1B 5B 31 4B	The characters between Cursors and line start will be deleted
				ESC [2 K 1B 5B 32 4B	Erase the hole line
(11)	VAR Pn1 mit Pn2 CHR.	1;4	Pn1 ; Pn2 V	ESC [7 ; 6 ; 2 ; 8 V 1B 5B 37 3B 36 3B 32 3B 38 56	Initialisation of The variable “7” as float with 6 figures length and 2 figures right of the comma
(12)	VAR Pn SET	1	Pn v STX var ETX	ESC [7 v STX 13 ETX 1B 5B 37 76 02 31 33 03	Set contents of variable „7“ to „13“
(13)	TEXT Pn STORE	1	Pn t STX text ETX	ESC [9 t STX S1 ETX 1B 5B 37 74 02 53 31 03	„S1“ is saved into the page No. 9
(14)	TEXT Pn RECALL	1	Pn T	ESC [9 T 1B 5B 39 54	Recall the page No. 9
				ESC [2 1 9 T 1B 5B 32 31 39 54	Recall the page No. 219
(15)	SET OUT- PUT 0/1	0	Pn X	ESC [0 X 1B 5B 30 58	The open collector output is open
				ESC [1 X 1B 5B 31 58	The open collector output is closed

Pn = Parameter : * = Default Parameter

4.8.1 Format text (Function 8)

The function „SET GR. RENDITION“ sets format for the actual page respectively the following characters. Normally the text has 4 rows with 40 columns. After the Sequence „ESC [1 m“ the display has only one line with a figure height of 65 mm. The sequence „ESC [2 2 m“ toggles back to normal display.

It is possible to let flash some words to increase their recognition. The sequence „ESC [5 m“ enables flashing with 1 Hz; the sequence „ESC [6 m“ with 2 Hz. The sequence „ESC [2 5 m“ stops flashing mode and shows the following characters normally.

4.8.2 Working with variables (function 11, 12)

The TA125 offers the ability to define fields in the text area as variables. Later the variables can be replaced by different contents, without uploading the whole page. The master has to send only the variable number and content and the TA125 replaces the variable on the defined place. This can be useful for process indications for instance.

The TA125 can manage 127 variables with a length of up to 10 characters. The sequence „ESC [7 ; 9 V“ defines for instance a variable No. 7 with a length of 9 characters on the actual cursor position. This place will be reserved on the display immediately.

Later the variable get its contents with the sequence „ESC [7 v STX CONTENTS ETX“ as often as the master will send this sequence.

4.8.3 Storing text pages (Function 13,14)

The TA125 stores up to 255 pages (max 32kByte) in its internal EPROM. The sequence „ESC [Pn t STX CONTENT ETX“ stores CONTENT in the page Pn.

This page can be recalled by the sequence „ESC [Pn T“.

The pages are kept in memory even after power down. To erase the pages overwrite it with a new content or use the hardware reset of the TA125, in this case all pages will be erased

4.8.4 Binary output (function 15)

The TA125 has a Open-Collector transistor out. This can be used for an acoustical actor for instance. The sequence „ESC [1 X“ closes the transistor and the sequence „ESC [0 X“ opens it.

5 Appendix

5.1 Technical Details

TA125

		Text display TA125
General	Ex- protection	E Ex ib IIC T6
	Group	II 2 G
	Certificate	TÜV 00 ATEX 1551
	Display	Text: 4 x 40 Characters View area 68 x 244 mm ²
Montage	Ambient temperature	-20°C ...+45°C T6 -20°C ...+65°C T4
	Zone	Hazardous area, Zone1
Housing	Dimensions H x B x T	TA125.0: 120mm x 360mm x 80mm
	Material	Aluminium, RAL 7035
	Protection	IP65
Electrical Specifications	Power supply (Kl. 1,2)	$U_i = 14V, I_i = 75 mA, C_i = 100 nF$
	Serial interface (Kl.3,4)	$U_i = 6V, I_i = 75 mA, C_i = 1,65 \mu F$
	Further conditions	Sum of the currents of terminal 1 and 3 = 75 mA
	Intrinsically safe output	$U_i = 30V, I_i = 160mA, P_i = 850 mW, L_i = 20\mu H,$ C_i ist negligible
	Binary Inputs	$U_0 = 6V, I_0 = 1mA, P_0 = 1,5 mW$ $C_0 = 60 \mu F, L_0 = 1000 mH$

TI125

		Text interface TI125
General	Mounting	Safe area
	Ex- protection	[E Ex ib]
	Certificate	TÜV 00 ATEX 1552
	Ambient temperature	-20°C ...+60°C
Housing	Dimensions H x B x T	101 x 100 x 66 mm ³
	Protection	IP65
	Material	Aluminium
	Fixing	35mm rail acc. EN50022
Electrical Specifications	Mains (Kl. 7-9)	230VAC, 120 VAC, 24 VDC
	Power consumption	ca. 9W
Ex i terminals	Power supply te. 1,2	$U_0 = 14V, I_0 = 75mA,$ rectangular characteristic $C_0 = 467 nF, L_0 = 0,13 mH$
	Serial interface	$U_0 = 6V, I_0 = 75mA,$ rectangular characteristic $C_0 = 1,867 \mu F, L_0 = 0,48 mH$
	Further conditions	Sum of the currents of terminal 1 and 3 = 75 mA
Interface module	Non Ex i terminals	RS232, RS485, Profibus DP, Interbus, Modbus

See also certificates TÜV 00 ATEX 1552 and TÜV 00 ATEX 1552

5.2 Dimensions

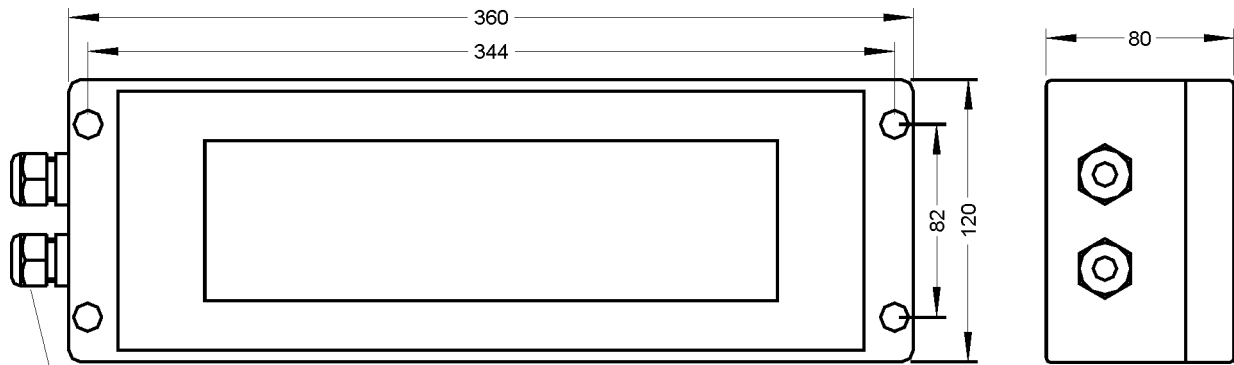

M16 x 1,5; SP: 5-10
Dimensions TA125.0

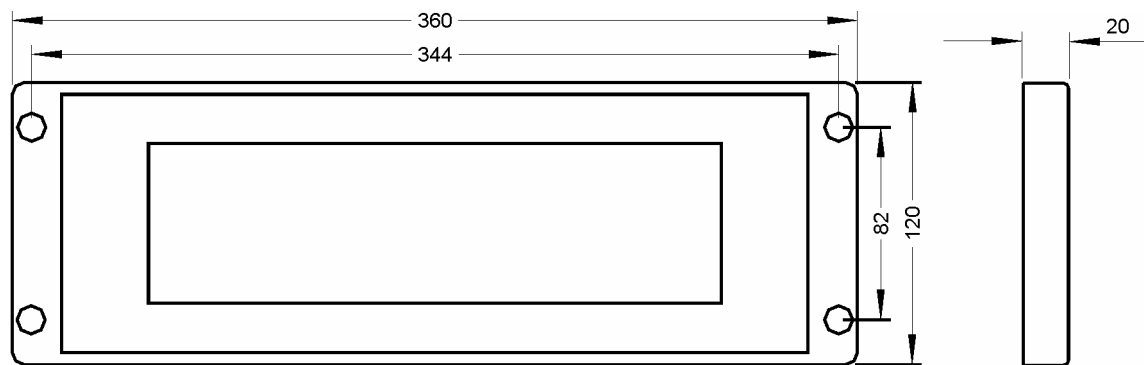

Dimensions TA125.0 for control panel mounting

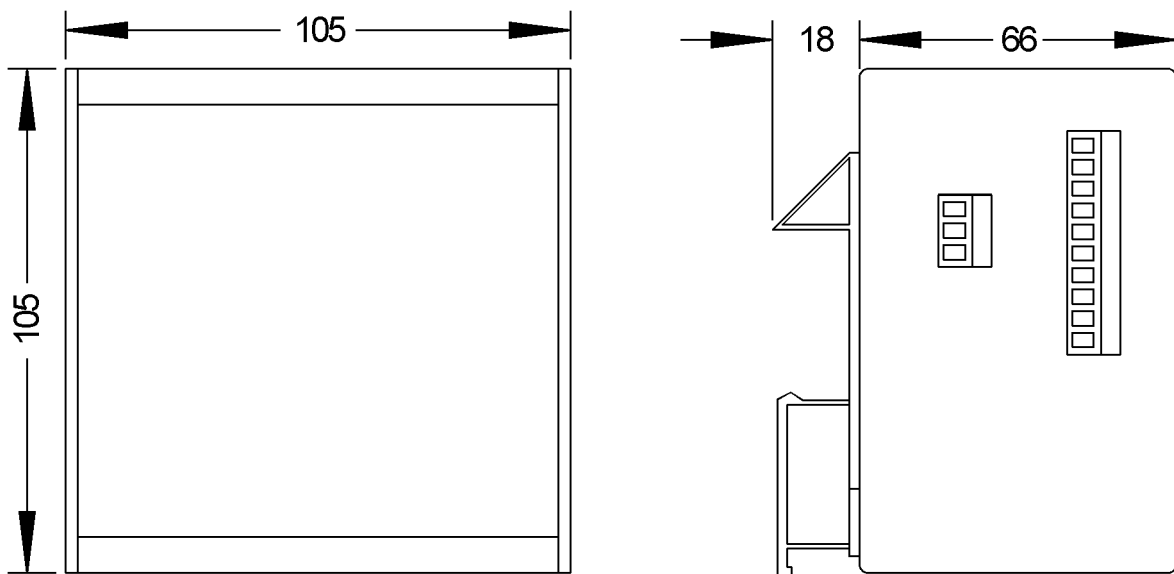

Dimensions TI125.x.x

5.3 Type code

Interface	TI125	.x	.x	.x
Mains:				
230 VAC.....		.0		
110 VAC3		
24 VDC6		
Interface module:				
RS485 / RS232 / RS4220		
Modbus1		
Profibus DP2		
Option binary address inputs: (to recall internally stored messages, only with TI125.x.0.x)				
Without0		
Present1		

More fieldbus types on request

Text display	TA125
IP 65 housing	TA125.0

More housing types on request

5.4 Block diagram

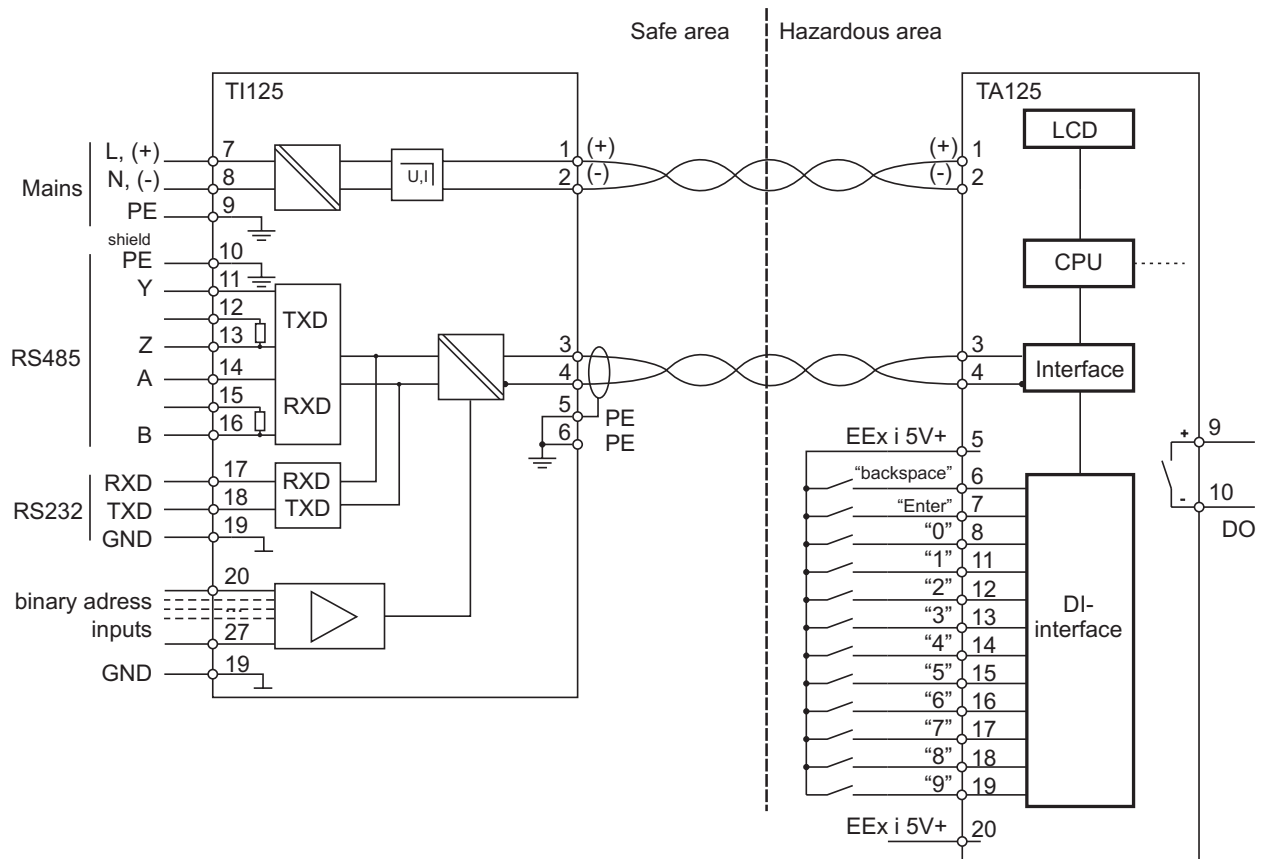

5.5 ASCII- character set of TA125

	0	1	2	3	4	5	6	7	8	9	A	B	C	D	E	F
0				0	1	P	`	F	E	W		°	À	0	À	À
1			!	1	À	Q	3	4	À	¡	±	À	À	À	À	À
2			"	2	B	R	b	r	W	Γ	♀	À	À	À	À	À
3			#	3	C	S	c	s	3	π	€	À	À	À	À	À
4			\$	4	O	T	t	H	Z	◊	À	À	À	À	À	À
5			%	5	E	U	e	u	Ï	σ	¥	À	À	À	À	À
6			&	6	F	V	f	v	Ï	À	9	À	À	À	À	À
7			'	7	G	W	w	Π	τ	∞	•	À	×	À	À	À
8			(8	H	X	h	x	∇	♣	♠	À	À	À	À	À
9)	9	I	Y	i	y	Π	À	À	À	À	À	À	À
A			*	:	J	Z	j	z	4	Q	Q	À	À	À	À	À
B			+	:	K	[k	[W	∞	∞	À	À	À	À	À
C			,	<	L	\	l	l	W	∞	À	À	À	À	À	À
D			-	=	M]	m]	b	♣	À	À	À	À	À	À
E			.	>	N	^	n	^	À	À	À	À	À	À	À	À
F			/	?	O	_	o	_	À	À	À	À	À	À	À	À



(1) **EG-Baumusterprüfbescheinigung**

- (2) Geräte und Schutzsysteme zur bestimmungsgemäßen Verwendung in explosionsgefährdeten Bereichen - **Richtlinie 94/9/EG**
- (3) EG Baumusterprüfbescheinigungsnummer



TÜV 00 ATEX 1551

- (4) Gerät: Textanzeige Typ TA 125.
- (5) Hersteller: Gönnheimer Electronic GmbH
- (6) Anschrift: D-67433 Neustadt/Weinstraße, Dr.-Julius Leber-Str.2
- (7) Die Bauart dieses Gerätes sowie die verschiedenen zulässigen Ausführungen sind in der Anlage zu dieser Baumusterprüfbescheinigung festgelegt.
- (8) Der TÜV Hannover/Sachsen-Anhalt e.V., TÜV CERT-Zertifizierungsstelle, bescheinigt als benannte Stelle Nr. 0032 nach Artikel 9 der Richtlinie des Rates der Europäischen Gemeinschaften vom 23. März 1994 (94/9/EG) die Erfüllung der grundlegenden Sicherheits- und Gesundheitsanforderungen für die Konzeption und den Bau von Geräten und Schutzsystemen zur bestimmungsgemäßen Verwendung in explosionsgefährdeten Bereichen gemäß Anhang II der Richtlinie.

Die Ergebnisse der Prüfung sind in dem vertraulichen Prüfbericht Nr. 00 PX 08100 festgelegt.

- (9) Die grundlegenden Sicherheits- und Gesundheitsanforderungen werden erfüllt durch Übereinstimmung mit

EN 50 014:1997 EN 50 020:1994

- (10) Falls das Zeichen "X" hinter der Bescheinigungsnummer steht, wird auf besondere Bedingungen für die sichere Anwendung des Gerätes in der Anlage zu dieser Bescheinigung hingewiesen.
- (11) Diese EG-Baumusterprüfbescheinigung bezieht sich nur auf die Konzeption und den Bau des festgelegten Gerätes gemäß Richtlinie 94/9/EG. Weitere Anforderungen dieser Richtlinie gelten für die Herstellung und das Inverkehrbringen dieses Gerätes.
- (12) Die Kennzeichnung des Gerätes muss die folgenden Angaben enthalten:

 **II 2 G EEx ib IIC T6**

TÜV Hannover/Sachsen-Anhalt e.V.
TÜV CERT-Zertifizierungsstelle
Am TÜV 1
D-30519 Hannover

Hannover, 10.04.2000

G. Kewel

Der Leiter



(13) **A N L A G E**

(14) **EG-Baumusterprüfbescheinigung Nr. TÜV 00 ATEX 1551**

(15) Beschreibung des Gerätes

Die Textanzeige Typ TA 125. dient zur Anzeige beliebiger Texte innerhalb des explosionsgefährdeten Bereiches der Kategorie 2 bzw. 3 (Zone 1 bzw. 2).

Die höchstzulässigen Umgebungstemperaturen betragen 45°C für die Temperaturklasse T6 und 65°C für die Temperaturklasse T4.

Elektrische Daten

Versorgungsstromkreis
(Klemme 1, 2)

in Zündschutzart Eigensicherheit EEx ib IIC
nur zum Anschluss an bescheinigte eigensichere
Stromkreise mit folgenden Höchstwerten:

$$U_i = 14 \text{ V}$$

$$I_i = 75 \text{ mA}$$

wirksame innere Kapazität 100 nF
Die wirksame innere Induktivität ist vernachlässigbar klein.

Serielle Schnittstelle
(Klemme 3, 4)

in Zündschutzart Eigensicherheit EEx ib IIC
nur zum Anschluss an bescheinigte eigensichere
Stromkreise mit folgenden Höchstwerten:

$$U_i = 6 \text{ V}$$

$$I_i = 75 \text{ mA}$$

wirksame innere Kapazität 1,66 µF
Die wirksame innere Induktivität ist vernachlässigbar klein.

Summe der Ströme an den Klemmen 1 bis 4: $\Sigma I_i \leq 75 \text{ mA}$

Digitaleingänge
(Klemme 5, 6; 5, 7; 5, 8)

in Zündschutzart Eigensicherheit EEx ib IIC
nur zum Anschluss passiver Schaltelemente
Höchstwerte:

$$U_o = 6 \text{ V}$$

$$I_o = 1 \text{ mA}$$

$$P_o = 1,5 \text{ mW}$$

Kennlinie: linear

höchstzul. äußere Induktivität 1 H
höchstzul. äußere Kapazität 60 µF

Anlage zur EG-Baumusterprüfbescheinigung Nr. TÜV 00 ATEX 1551

Digitalausgang
(Klemme 9, 10)

in Zündschutzart Eigensicherheit EEx ib IIC
nur zum Anschluss an bescheinigte eigensichere
Stromkreise mit folgenden Höchstwerten:

$$U_i = 30 \text{ V}$$

$$I_i = 160 \text{ mA}$$

$$P_i = 850 \text{ mW}$$

Die wirksame innere Induktivität und Kapazität sind vernachlässigbar klein.

Der Digitalausgang ist von allen übrigen Stromkreisen bis zu einem Scheitelwert der Nennspannung von 60 V sicher galvanisch getrennt.

(16) Prüfungsunterlagen sind im Prüfbericht Nr. 00 PX 08100 aufgelistet.

(17) Besondere Bedingung

keine

(18) Grundlegende Sicherheits- und Gesundheitsanforderungen

keine zusätzlichen



1. E R G Ä N Z U N G
ZUR
EG-Baumusterprüfbescheinigung Nr. TÜV 00 ATEX 1551

der Firma: Gönzheimer Elektronik GmbH
Dr.-Julius Leber-Str.2
D-67433 Neustadt/Weinstraße

Die Textanzeige Typ TA 125. darf künftig auch entsprechend den im Prüfbericht aufgelisteten Unterlagen gefertigt werden.

Die Änderungen betreffen den inneren Aufbau. Die Anzahl der Digitaleingänge wird auf 12 erhöht.

Elektrische Daten

Digitaleingänge
(Klemme 5, 6; 5, 7; 5, 8
20, 11; 20, 12; 20, 13:
20, 14; 20, 15; 20,16;
20, 17; 20, 18; 20,19)

in Zündschutzart Eigensicherheit EEx ib IIC
nur zum Anschluss passiver Schaltelemente

Höchstwerte:

$U_o = 6 \text{ V}$

$I_o = 1 \text{ mA}$

$P_o = 1,5 \text{ mW}$

Kennlinie: linear

höchstzul. äußere Induktivität 1 H

höchstzul. äußere Kapazität 60 μF

Alle weiteren elektrischen Daten und Angaben gelten unverändert für diese Ergänzung.

(16) Prüfungsunterlagen sind im Prüfprotokoll Nr. 02 YEX 193640 aufgelistet.

(17) Besondere Bedingungen

keine

(18) Grundlegende Sicherheits- und Gesundheitsanforderungen

keine zusätzlichen

TÜV NORD CERT GmbH & Co. KG
TÜV CERT-Zertifizierungsstelle
Am TÜV 1
D-30519 Hannover
Tel.: 0511 986-1470
Fax: 0511 986-2555

Hannover, 27.09.2002

Der Leiter



2. E R G Ä N Z U N G
zur
EG-Baumusterprüfbescheinigung Nr. TÜV 00 ATEX 1551

der Firma: Gönzheimer Elektronik GmbH
Dr.-Julius Leber-Str.2
D-67433 Neustadt/Weinstraße

Die Textanzeige Typ TA 125. darf künftig auch entsprechend den im Prüfbericht aufgelisteten Unterlagen gefertigt werden.

Die Änderungen betreffen den Einsatz in durch Staub explosionsgefährdete Bereiche und damit die Erweiterung der Kennzeichnung.

Diese lautet: **II 2 D T 70°C IP65** bei einer höchstzulässigen Umgebungstemperatur von 65°C.

Die elektrischen Daten und alle weiteren Angaben gelten unverändert für diese Ergänzung.

Prüfungsunterlagen sind im Prüfprotokoll Nr. 03 YEX 550597 aufgelistet.

TÜV NORD CERT GmbH & Co. KG
TÜV CERT-Zertifizierungsstelle
Am TÜV 1
D-30519 Hannover
Tel.: 0511 986-1470
Fax: 0511 986-2555

Hannover, 21.03.2003

A handwritten signature in black ink, appearing to read 'G. K. W. L.' or similar.

Der Leiter



(1) EG-Baumusterprüfbescheinigung

- (2) Geräte und Schutzsysteme zur bestimmungsgemäßen Verwendung in explosionsgefährdeten Bereichen - **Richtlinie 94/9/EG**
- (3) EG Baumusterprüfbescheinigungsnummer



TÜV 00 ATEX 1552

- (4) Gerät: Textanzeige-Interface Typ TI 125...
- (5) Hersteller: Gönzheimer Elektronik GmbH
- (6) Anschrift: D-67433 Neustadt/Weinstraße, Dr.-Julius Leber-Str.2
- (7) Die Bauart dieses Gerätes sowie die verschiedenen zulässigen Ausführungen sind in der Anlage zu dieser Baumusterprüfbescheinigung festgelegt.
- (8) Der TÜV Hannover/Sachsen-Anhalt e.V., TÜV CERT-Zertifizierungsstelle, bescheinigt als benannte Stelle Nr. 0032 nach Artikel 9 der Richtlinie des Rates der Europäischen Gemeinschaften vom 23. März 1994 (94/9/EG) die Erfüllung der grundlegenden Sicherheits- und Gesundheitsanforderungen für die Konzeption und den Bau von Geräten und Schutzsystemen zur bestimmungsgemäßen Verwendung in explosionsgefährdeten Bereichen gemäß Anhang II der Richtlinie.
- Die Ergebnisse der Prüfung sind in dem vertraulichen Prüfbericht Nr. 00 PX 08200 festgelegt.
- (9) Die grundlegenden Sicherheits- und Gesundheitsanforderungen werden erfüllt durch Übereinstimmung mit
- EN 50 014:1997 EN 50 020:1994**
- (10) Falls das Zeichen "X" hinter der Bescheinigungsnummer steht, wird auf besondere Bedingungen für die sichere Anwendung des Gerätes in der Anlage zu dieser Bescheinigung hingewiesen.
- (11) Diese EG-Baumusterprüfbescheinigung bezieht sich nur auf die Konzeption und den Bau des festgelegten Gerätes gemäß Richtlinie 94/9/EG. Weitere Anforderungen dieser Richtlinie gelten für die Herstellung und das Inverkehrbringen dieses Gerätes.
- (12) Die Kennzeichnung des Gerätes muss die folgenden Angaben enthalten:

 II (2) G [EEx ib] IIC

TÜV Hannover/Sachsen-Anhalt e.V.
TÜV CERT-Zertifizierungsstelle
Am TÜV 1
D-30519 Hannover

Hannover, 10.04.2000



Der Leiter





(13)

ANLAGE

(14) **EG-Baumusterprüfbescheinigung Nr. TÜV 00 ATEX 1552**

(15) Beschreibung des Gerätes

Die Textanzeige-Interface Typ TI 125... dient als Versorgungs-Interface zwischen einem Textserver im sicheren Bereich und der Textanzeige im explosionsgefährdeten Bereich der Kategorie 2 bzw. 3 (Zone 1 bzw. 2).

Die höchstzulässige Umgebungstemperatur beträgt 60°C.

Elektrische Daten

Netzstromkreis
(Klemme 7, 8, 9)

$U = 110$ bzw. 230 V AC
 $U = 24$ VDC
je nach Ausführung

$U_m = 253$ VAC
 $U_m = 125$ VDC

MOD1 Anschlüsse

$U_m = 253$ VAC

Speisestromkreis
(Klemme 1, 2)

in Zündschutzart Eigensicherheit EEx ib IIC
Höchstwerte:
 $U_o = 13,7$ V
 $I_o = 75$ mA

Die Werte für die höchstzul. äußere Kapazität und Induktivität sind der folgenden Tabelle zu entnehmen:

C_o	467 nF
L_o	0,13 mH
C_o	267 nF
L_o	0,48 mH

Serielle Schnittstelle
(Klemme 3, 4)

in Zündschutzart Eigensicherheit EEx ib IIC
Höchstwerte:
 $U_o = 6$ V
 $I_o = 75$ mA

höchstzul. äußere Kapazität 1,87 μ F
höchstzul. äußere Induktivität 0,48 mH

Die Summe der Ströme an den Klemmen 1 bis 4 ist ≤ 75 mA.

Die eigensicheren Stromkreise sind von allen übrigen Stromkreisen bis zu einem Scheitelwert der Nennspannung von 375 V sicher galvanisch getrennt.

Anlage zur EG-Baumusterprüfbescheinigung Nr. TÜV 00 ATEX 1552

(16) Prüfungsunterlagen sind im Prüfbericht Nr.: 00 PX 08200 aufgelistet.

(17) Besondere Bedingung

keine

(18) Grundlegende Sicherheits- und Gesundheitsanforderungen

keine zusätzlichen